

CUSTOMER COPY

REV.	DESCRIPTION	APP.	DATE
A	NEW DESIGN	Amos	2012-12-11

ORDER INFORMATION

1212 4 3 1 XX X

- 1:Plating Tin
- 3:Plating Gold Flash
- No. of Contact
- 1:W/O Kink/White
- 180° SMT Style
- Type

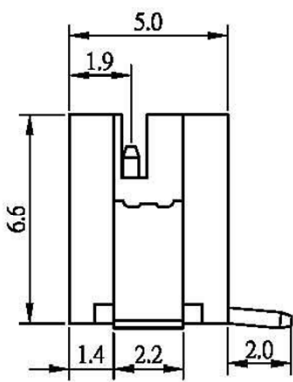
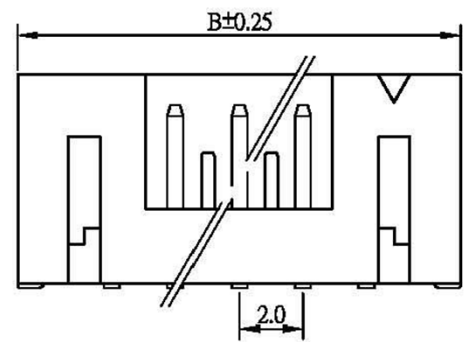
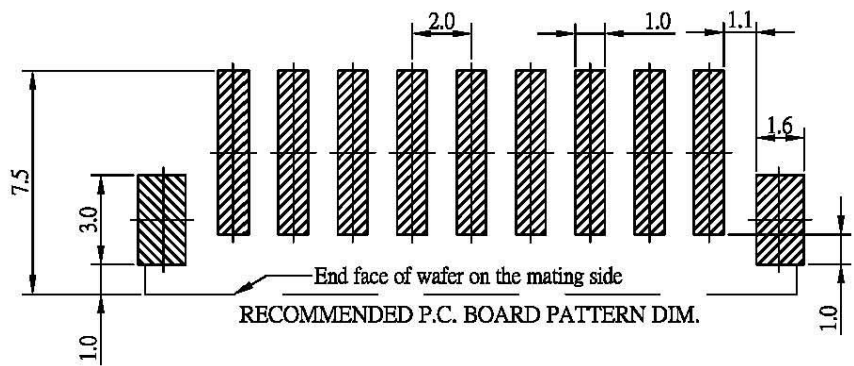
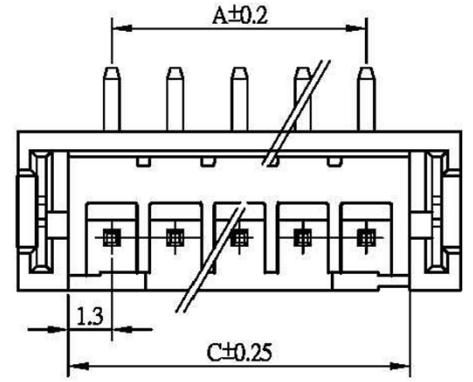

SPECIFICATIONS

Electrical

- Voltage Rating: 100V AC, DC
- Current Rating: 2A AC, DC
- Withstand Voltage: 800V AC/min
- Insulation Resistance: 1000M Ω/min
- Temperature Range: -25°C ~ +85°C

Material

- Wafer: High Temperature Plastic Nylon 46 or 6T UL94V-0
- Pin: High Strength Brass With Tin Over Nickel Plated
- Applicable PC Board Thickness: 0.8 ~ 1.6mm
- Contact Resistance: Initial Value / 10mΩ max.
- After environmental testing 20mΩ max.

CKT.	A	B	C
2	2.00	8.00	4.80
3	4.00	10.00	6.80
4	6.00	12.00	8.80
5	8.00	14.00	10.80
6	10.00	16.00	12.80
7	12.00	18.00	14.80
8	14.00	20.00	16.80
9	16.00	22.00	18.80
10	18.00	24.00	20.80
11	20.00	26.00	22.80
12	22.00	28.00	24.80
13	24.00	30.00	26.80
14	26.00	32.00	28.80
15	28.00	34.00	30.80
16	30.00	36.00	32.80

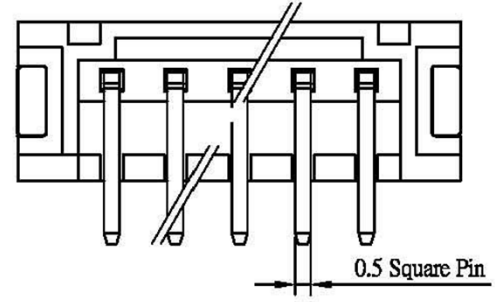

 鈺滿榮企業股份有限公司 ACMELUX CO., LTD.
 TEL:886-2-85124595 FAX:886-2-85124322

0.0±0.35	SCALE: 1:1	TITLE:	PART NO:
0.00±0.25	UNIT: mm	Pitch 2.0mm 180° SMT SM3 Type	APP BY: <i>Hung</i>
0.000±0.15		Wafer Connector	CHK BY: <i>Cheryl</i>
		MATL: RoHS	DR BY: <i>Amos</i>
		DWG. NO. C1212431XXX	A303